



Bambi
BUCKET®
Driven by Innovation

SEI
INDUSTRIES



SACKSAFOAM HELI-CASE
OPERATIONS MANUAL
2024A

SACKSAFOAM HELI-CASE OPERATIONS MANUAL

Version: 2024A
Part Number: 015382

PLEASE READ BEFORE USING

This manual is applicable to the following models:

SFX (# 012743)

Physical copies of this manual (# 015382) are available from SEI.

The manual is available on the SEI website.

Register for manual update notifications at bambiupdate@sei-ind.com

This manual is based on information that was available at the time it was printed and may not be applicable to products received before the issue date and customized items.

SEI INDUSTRIES LTD.

7400 Wilson Avenue
Delta, B.C. Canada
V4G 1H3

Phone: (604) 946-3131
Fax: (604) 940-9566
E-Mail: seisales@sei-ind.com
Website: www.bambibucket.com

Revision Summary

Version	Release Date	Revision Description	Pages	App.
2019A	18-Mar-2019	<ul style="list-style-type: none">• General Revision	-	AW
2023A	01-May-2023	<ul style="list-style-type: none">• Corrected error in SF Plus Switch description of operation	6	MDT
2024A	26-Jun-2024	<ul style="list-style-type: none">• Replaced controller	10-12	MDT

Table of Contents

Section 1: Overview	1
Introduction.....	1
Specifications	2
Major Components.....	3
Control Panel Overview.....	4
Section 2: Installation	7
Controller Setup.....	8
Section 3: Filling	11
Automatic Filling	11
Manual Filling.....	11
Section 4: Operations	12
Using the Controller.....	12
Section 5: Clean Up & Storage	14
Clean up	14
Long term Storage.....	14
Section 6: Drawings	15
Section 7: Warranty	16

Section 1: Overview

Introduction



The Sacksafoam Heli-Case is designed to be used inside helicopters to supply foam concentrate to Bambi buckets. The Sacksafoam Heli-Case will hold up to 25 USG (95 litres) of foam concentrate. The Sacksafoam Heli-Case is compatible with Bambi Bucket models 2024 through HL5000.

The foam concentrate is stored in a 20 gallon tank inside a large plastic case with provision for an extra 5 USG container. The system is self-contained and designed to prevent foam from contacting the helicopter.

The Sacksafoam Heli-Case interfaces with the Sacksafoam Controller to accurately dispense the desired volume of concentrate for various Bambi Bucket models. The Sacksafoam controller can be mounted directly in the Sacksafoam Heli-Case control panel or externally by using the supplied blanking plate and harnesses. Dispensing can be controlled directly from the Sacksafoam controller screen and can also be triggered using the red button on the remote control grip.

The Sacksafoam Heli-Case can also interface with the standard Bambi Bucket and Bambi Max Bucket. The buckets can be actuated using the trigger on the remote control grip.

Specifications

Empty Weight	76 lb	35 kg
Empty Weight without Lid	62 lb	28 kg
Gross Weight	267 lb	122 kg
Concentrate Capacity	23 USG	87 L
Dispense Rate	15 GPM	0.93 L/s
Max Current	20A	
Voltage	24-28 VDC	

Section 1: Overview

Major Components

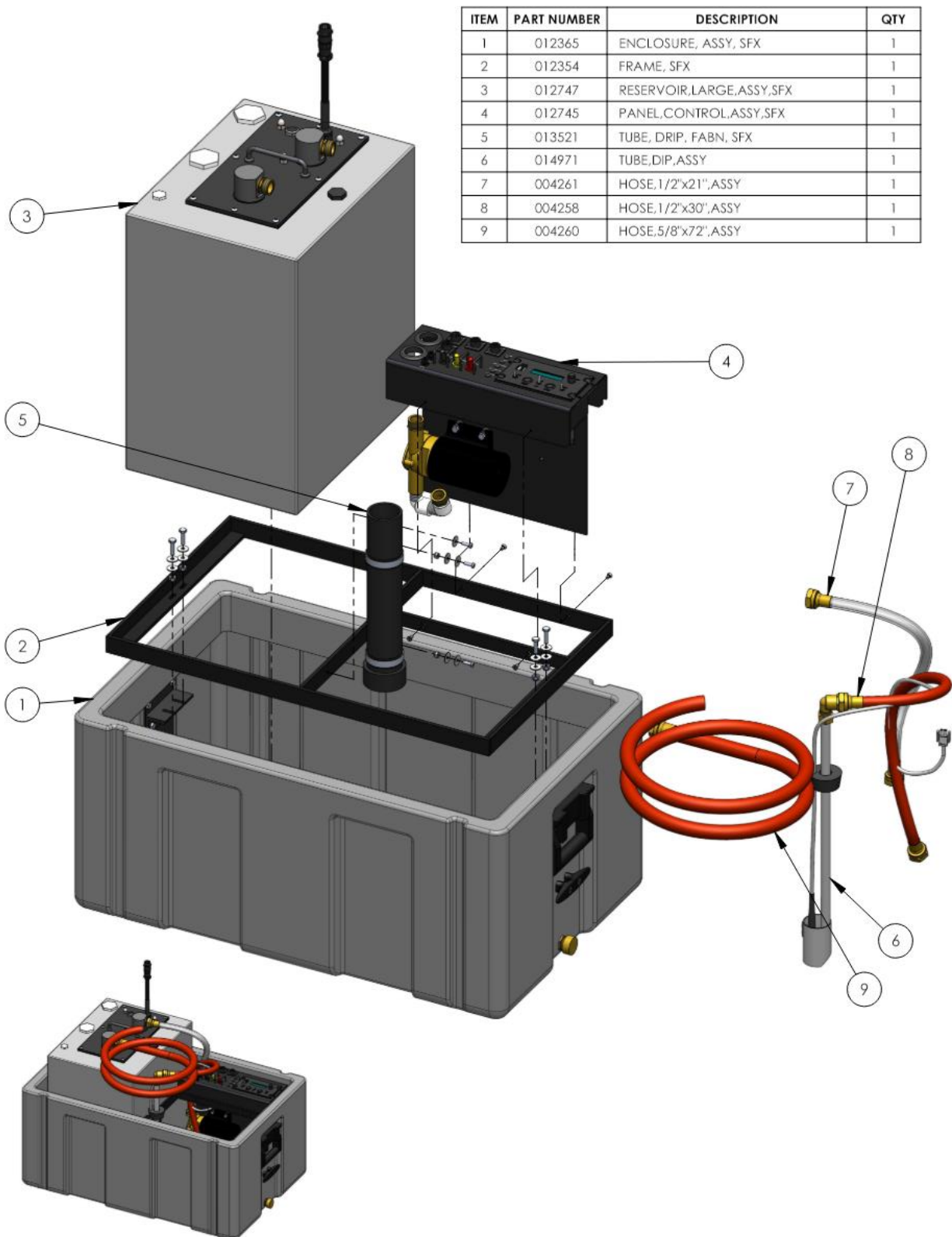

ITEM	PART NUMBER	DESCRIPTION	QTY
1	012365	ENCLOSURE, ASSY, SFX	1
2	012354	FRAME, SFX	1
3	012747	RESERVOIR,LARGE,ASSY,SFX	1
4	012745	PANEL,CONTROL,ASSY,SFX	1
5	013521	TUBE, DRIP, FABN, SFX	1
6	014971	TUBE,DIP,ASSY	1
7	004261	HOSE,1/2"x21",ASSY	1
8	004258	HOSE,1/2"x30",ASSY	1
9	004260	HOSE,5/8"x72",ASSY	1

Section 1: Overview

Control Panel Overview



Figure 1-Control Panel

The Sacksafoam control panel houses the Sacksafoam Controller (or a blanking plate with a connector), the connectors for interface harnesses, circuit breakers, switches, and indicators needed to operate the system. The various components are described below:

Circuit Breakers

Foam Circuit Breaker: This 10 amp circuit breaker provides circuit protection for the Sacksafoam Heli-Case system. The breaker must be depressed for the Sacksafoam Heli-Case and a connected Bambi Bucket to operate.

Bambi Circuit Breaker: This 5 amp circuit breaker provides circuit protection for a Standard Bambi Bucket or Bambi Max Bucket that is connected to the Sacksafoam Heli-Case system. It must be depressed for a connected Bambi Bucket to operate.

Section 1: Overview

Interface Connectors

Power connector: This connector interfaces with harness 013509 and supplies power to the Sacksafoam system as well as any Bambi Bucket connected to the Sacksafoam system

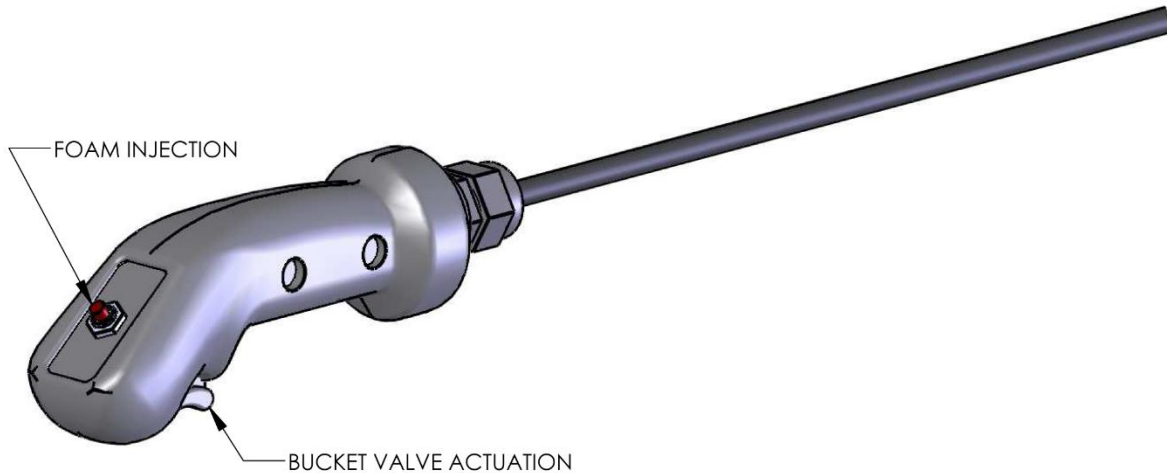

Figure 2-Sacksafoam Heli-Case Remote Control Grip 013510

Control Connector: This connector interfaces with the Remote Control Grip 013510. The remote control grip can be used to initiate foam injection and to actuate the valve on a standard Bambi Bucket or Bambi Max Bucket. Foam Injection is initiated by depressing the red push button switch at the top of the control grip. The bucket valve is actuated by using the trigger switch on the control grip.

Bambi Connector: This connector interfaces with the Bambi Bucket harness 013511, which interfaces with a Standard Bambi or Bambi Max control cable or longline cable.

SF Plus Connector: This connector interfaces with a Sacksafoam Plus dip tube.

LED Indicators

Power Indicator: This LED will illuminate green when the Sacksafoam System has power.

SF Plus Indicator: This LED will illuminate green to indicate when the Sacksafoam Plus Dip Tube sensor is being used instead of the Sacksafoam Heli-Case dip tube sensor. This is controlled using the SF Plus toggle switch.

Transfer Pump Indicator: This LED will illuminate yellow when the transfer pump is running.

Dip Tube Low Indicator: This LED will illuminate red when the selected dip tube (either the Sacksafoam Heli-Case dip tube or the SF Plus dip tube) is below its low fluid level.

Low Tank Indicator: This LED will illuminate red when the tank is below its low fluid level.

Section 1: Overview

Switches

SF Plus Switch: This toggle switch selects which dip tube sensor the system uses to control the transfer pump. When toggled down, the SF Plus light will be illuminated and the system will read the SF plus dip tube signal. If no SF Plus is being used, the Dip Tube Low indicator will always be illuminated in this condition. When toggled up, the system will read the Sacksafoam Heli-Case dip tube signal.

Override Switch: This momentary switch can be pressed and held to run the transfer pump at any time regardless of dip tube or tank levels. The transfer pump will stop running when the switch is released.

Drain Switch: Pressing and holding this momentary switch for a second will initiate the drain sequence, which will run the dispense pump until the tank reaches the low level.

Section 2: Installation

Section 2: Installation

The Sacksafoam Heli-Case can run on 24-28 VDC. The Sacksafoam Heli-Case should be connected to a circuit capable of handling up to 20 amps. Use the harness 013509 provided with the Sacksafoam Heli-Case to connect it to your Power Supply. The white wire should be connected to 24-28 VDC while the black wire should be connected to aircraft ground. See *Section 6: Drawings* for reference.

The system can be secured to the floor of the helicopter using the two tie down cleats on the outside of the enclosure.



Figure 3-Tie down cleat and enclosure handle

The system includes enough hose to reach the outside of the helicopter. The customer is responsible for providing a 5/8" garden hose that will run from the belly hook to the inside of the bucket. The two hoses should be joined using a barbed connector without clamps. This will allow the hoses to disconnect if the bucket is released from the hook in an emergency. Secure the bucket side hose to the IDS deployment cable using zip ties.



Figure 4-Installing the barbed fitting

Section 2: Installation

A Standard Bambi Bucket or Bambi Max Bucket can interface with the Sacksafoam Heli-Case using the Bambi Harness 013511 provided with the Sacksafoam Heli-Case. The harness is connected directly to the Sacksafoam Heli-Case control panel, and allows the bucket to be operated using the remote control grip included with the Sacksafoam Heli-Case. The bucket will draw power from the same power supply as the Sacksafoam Heli-Case, but is protected by its own 5 amp circuit breaker on the control panel.



Figure 6-Control Panel

Controller Setup

It will be necessary to adjust some of the controller settings to suit the user's particular installation. Once saved, these settings will be the default settings the next time the unit is powered on.

The settings are changed by accessing the menu system. Depending on the user's selection of options, some other menu items may not display.

Units of Measurement

The controller can be set to operate using US Gallons or Liters:

- Press the **SETTINGS** knob to enter the menu system.
- Rotate the **SETTINGS** knob until "UNITS" is displayed in the upper line of the display.
- Press the **SETTINGS** knob to enter the **UNITS** menu item.
- Rotate the **SETTINGS** knob to select the units in the lower line of the display.
- Press the **SETTINGS** knob to save and exit the menu system.

Section 2: Installation

Bucket Model / Capacity

The controller displays both the bucket model number and bucket capacity in the user's selected units.

- Press the **SETTINGS** knob to enter the menu system.
- Rotate the **SETTINGS** knob until “**BUCKET CAPACITY**” is displayed in the upper line of the display.
- Press the **SETTINGS** knob to enter the **BUCKET CAPACITY** menu item.
- Rotate the **SETTINGS** knob to select the bucket model / capacity in the lower line of the display.
- Press the **SETTINGS** knob to save and exit the menu system.

Valve Type

Selecting the valve type disables any features that are not available with the user's valve and removes the features from the menu system to reduce clutter.

- Press the **SETTINGS** knob to enter the menu system.
- Rotate the **SETTINGS** knob until “**VALVE TYPE**” is displayed in the upper line of the display.
- Press the **SETTINGS** knob to enter the **VALVE TYPE** menu item.
- Rotate the **SETTINGS** knob to select the valve type in the lower line of the display.
- Press the **SETTINGS** knob to save and exit the menu system.

Foam Reservoir Capacity

The controller displays the foam concentrate reservoir capacity in the user selected units.

- Press the **SETTINGS** knob to enter the menu system.
- Rotate the **SETTINGS** knob until “**FOAM RESERVOIR**” is displayed in the upper line of the display.
- Press the **SETTINGS** knob to enter the **FOAM RESERVOIR** menu item.
- Rotate the **SETTINGS** knob to select **20 USG HELICASE** or **76 L HELICASE**.
- Press the **SETTINGS** knob to save and exit the menu system.

Section 2: Installation

Display Backlight

The display backlight can be adjusted to suit ambient lighting conditions.

- Press the **SETTINGS** knob to enter the menu system.
- Rotate the **SETTINGS** knob until “**BACKLIGHT**” is displayed in the upper line of the display.
- Press the **SETTINGS** knob to enter the **BACKLIGHT** menu item.
- Rotate the **SETTINGS** knob to adjust the backlight brightness in the lower line of the display.
- Press the **SETTINGS** knob to save and exit the menu system.

Section 3: Filling

Section 3: Filling

The Sacksafoam Heli-Case has a built-in transfer pump for filling the tank with concentrate. The transfer pump is located under the control panel face and moves fluid through the dip tube and into the tank when activated.

Automatic Filling

The standard method of filling the Sacksafoam tank is by using the automated filling function. Follow the steps below to fill the Sacksafoam tank:

1. With the Sacksafoam Heli-Case installed in the helicopter and connected to power, depress the 10 amp circuit breaker. You should see the green “POWER” indicator, the red “DIP TUBE LOW” indicator and the “LOW TANK” indicator all illuminated. If the green “SF PLUS” indicator is also illuminated, toggle the SF PLUS switch.
2. Place a 5 gallon container of concentrate in the enclosure and insert the dip tube. The “DIP TUBE LOW” indicator should turn off and the transfer pump should start automatically. The “TRANSFER PUMP” indicator should be illuminated yellow.
3. The transfer pump will stop and the “DIP TUBE LOW” indicator will illuminate again when the container is emptied or the dip tube is removed from it. Transfer the dip tube to the dip tube holder and replace the container with a new one.
4. Repeat steps 2 and 3 until the tank is full. The transfer pump will stop automatically when the tank is full. The transfer pump will not run automatically again until the tank reaches the low level.
5. The dip tube can be left in the 5 gallon container during operations to increase total capacity.

Manual Filling

The override switch can be pressed and held to run the transfer pump at any time regardless of dip tube or tank levels. The transfer pump will stop running when the switch is released. Caution should be taken not to overfill the tank or run the transfer pump dry.

The tank can also be filled manually by pouring in fluid directly through the large port on the top of the tank.

Section 4: Operations

Using the Controller

Turning on the Controller

- Actuate the **ON/OFF** toggle switch to the **ON** position.

Setting Foam Percentage

The foam mix ratio is adjustable between 0.1% and 1.5% in 0.1% increments.

- Press the **SETTINGS** knob to enter the menu system.
- Rotate the **SETTINGS** knob until “**FOAM CONTROL**” is displayed in the upper line of the display.
- Press the **SETTINGS** knob to enter the **FOAM CONTROL** menu item.
- Rotate the **SETTINGS** knob to select the mix ratio in the lower display line.
- Press the **SETTINGS** knob to save and exit the menu system.

Initiating Foam Injection

Foam injection can be initiated by either:

- Momentarily actuating the “**FOAM**” toggle switch, or
- Momentarily actuating the foam injection button on the remote control grip

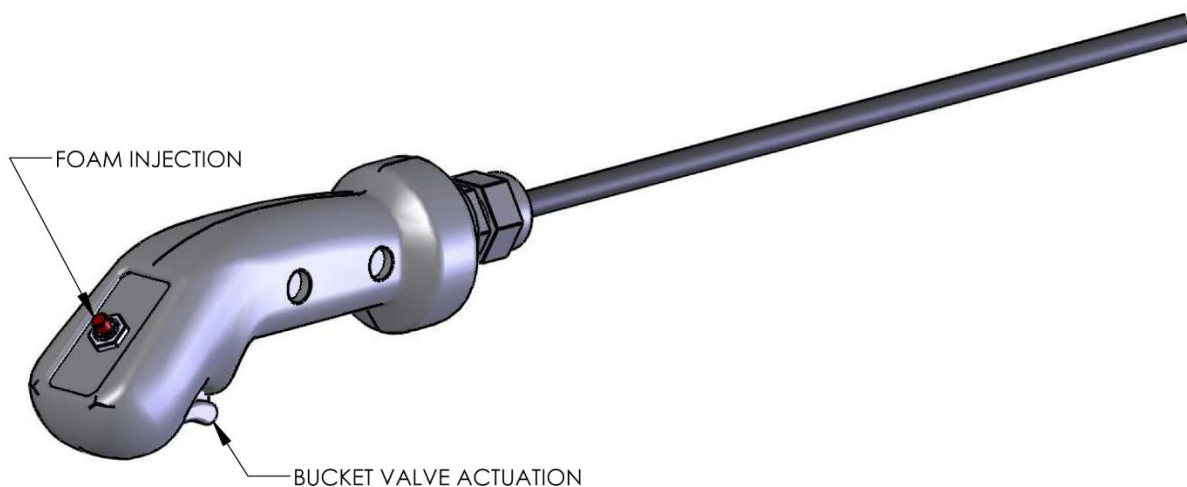

While the injection pump is operating, the lower line of the display will indicate the selected foam mix ratio (e.g. “**INJECT FOAM 0.7%**”).

Section 4: Operations

Counting Foam Drops

The controller has two counters for automatically counting the foam drops. Every time a foam pump injection cycle is completed, the foam counters will automatically increment. The values of the current foam counts are displayed in the lower line of the display (e.g. “058 FOAM 007”).

Each counter can be independently reset by pressing the “**RESET**” button located below the counter. The values of these counters are maintained in memory when the controller is powered off.

Counting Bucket Drops

The controller also has two counters for manually counting bucket drops. To increment the counts, momentarily actuate the “**TARE**” toggle switch. The values of the current bucket counts are displayed in the upper line of the display (e.g. “362 BUCKET 436”).

Each counter can be independently reset by pressing and holding the “**RESET**” button located below the counter. The values of these counters are maintained in memory when the controller is powered off.

Section 5: Clean Up & Storage

Clean up

The Sacksafoam Heli-Case should be cleared of foam concentrate and rinsed with fresh water at the end of a mission. To drain and rinse the tank follow the procedure below:

1. Remove the dip tube from any source of foam concentrate.
2. Use the red drain switch on the control panel. This will run the dispense pump until tank reaches its low level.
3. Drain any remaining fluid by running the dispense pump with the controller and a concentration setting of 0.1% until the dispense pump can no longer draw fluid.
4. Fill the tank with water using the automatic filling procedure described in the Automatic Filling section on page 11.
5. Remove the dip tube from the water source.
6. Use the drain switch again to rinse the system.
7. Drain any remaining fluid by running the dispense pump with the controller and a concentration setting of 0.1% until the dispense pump can no longer draw fluid.
8. Disconnect the tank electrical harness and inlet hose.
9. Remove the tank from the enclosure.
10. Remove the large PVC cap on the tank and pour out any excess fluid.

Long term Storage

The Sacksafoam Heli-Case should be completely dry before going into storage for more than three weeks. Follow the procedure below to ensure that your Sacksafoam Heli-Case is ready for long term storage:

1. Disconnect the tank inlet hose and tank electrical harness.
2. Remove the eight screws that secure the dispense assembly to the tank.
3. Carefully remove the dispense assembly from the tank. The assembly must be rotated for the base plate to clear the tank opening.
4. Use a rag or towel to dry the inside of the tank.
5. Reinstall the dispense assembly.
6. Remove the large PVC cap on the tank and leave it in the enclosure.
7. Close the enclosure and store the system.

Section 6: Drawings

Section 6: Drawings

Sacksafoam Heli-Case Wiring Diagram

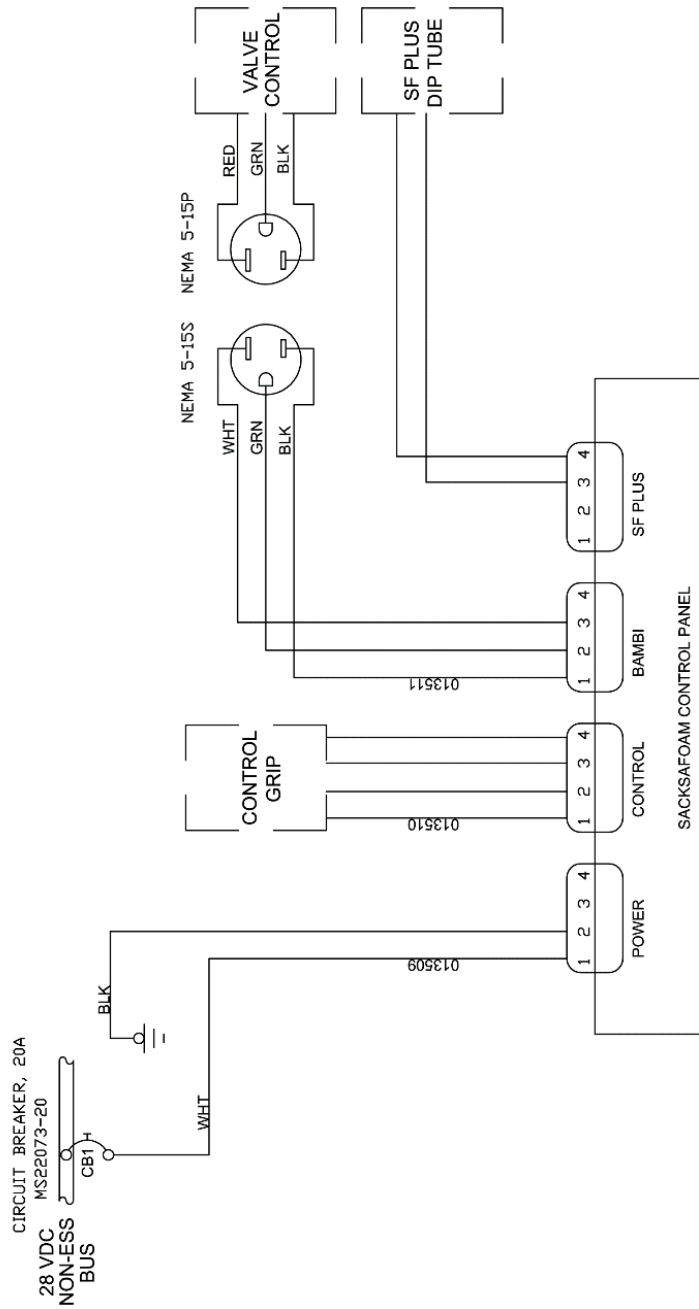

NOTES

1. THESE ARE RECOMMENDED INSTALLATION INSTRUCTIONS ONLY. ALL INSTALLATIONS TO BE DONE BY QUALIFIED PERSONNEL IN ACCORDANCE WITH APPLICABLE LOCAL REGULATIONS.
2. CONNECTION TO AIRCRAFT POWER SUPPLY DONE IN ACCORDANCE WITH FAA ADVISORY CIRCULAR AC43.13-1B AND AC43.12-2A. DO NOT CONNECT THE BAMBİ SYSTEM TO ANY AIRCRAFT BUS BAR THAT IS USED FOR EMERGENCY OR ESSENTIAL LOADS. AMMEND THE AIRCRAFT ELECTRICAL LOAD ANALYSIS TO ENSURE THAT THE GENERATOR CAPACITY IS ADEQUATE TO OPERATE THE SYSTEM.
3. ALL GROUNDS, SOLDERED TERMINALS, AND CRIMPED TERMINALS DONE IN ACCORDANCE WITH AIRCRAFT MANUFACTURER'S INSTRUCTIONS.

Section 7: Warranty

Section 7: Warranty

SEI Industries Ltd. (the company) agrees to grant a warranty for a period of one year from the date of purchase of Bambi bucket systems on the following conditions:

- a) The company's sole obligation under this warranty is limited to repairing or replacing, at the company's sole discretion, any product shown to be defective.
- b) The company's products are not guaranteed for any specific length of time or measure of service, but are warranted only to be free from defects in workmanship and material for a period of one year to the original purchaser.
- c) To the extent allowable under applicable law, the company's liability for consequential and incidental damages is expressly disclaimed. **The company's liability in all events is limited to and shall not exceed, the purchase price paid.**
- d) This warranty is granted to the original purchaser of Bambi bucket systems and does not extend to a subsequent purchaser or assignee.
- e) The company must receive notification in writing of any claims of warranty from the original purchaser which must give details of the claimed defect in the product.
- f) Where the original purchaser is claiming under warranty, the product must be returned to the company for inspection with all transportation and duty charges prepaid.
- g) The warranty does not extend to any product that has been accidentally damaged, abraded, altered, punctured, abused, misused or used for a purpose which has not been approved by the company.
- h) This warranty does not apply to any accessories used with the product that are not supplied by the company and any warranty on such accessories must be requested from the manufacturer or dealer of the accessories.
- i) In the event the original purchaser does not give notice of a warranty claim, within one year of the original purchase of the product, it is understood that the purchaser has waived the claim for warranty and the purchaser and/or any subsequent purchaser must accept the condition of the product, without warranty.
- j) Any technical information supplied by the company regarding the product is not a condition of warranty but rather is information provided by the company to the best of its knowledge.
- k) There are no implied warranties nor is there any warranty that can be assumed from any representation of any person, except the company itself.

Exclusions

- l) This warranty is void if the product is not installed, used and/or maintained in accordance with the operations manual supplied by SEI.